

What is mechanics

• ***Mechanics*** is the study of force, deformation, and motion, and the relations between them. We care about forces because we want to know how hard to push something to move it or whether it will break when we push on it for other reasons. We care about deformation and motion because we want things to move or not move in certain ways. Towards these ends we are confronted with

this general mechanics problem: In mechanics we try to solve special cases of the general mechanics problem above by idealizing the system, using classical Euclidean geometry to describe deformation and motion, and assuming that the relation between force and motion is described with Newtonian mechanics, Any mechanics problem can be divided into 3 parts which

we think of as the 3 pillars that hold up the subject:

- 1 the mechanical behavior of objects and materials (*constitutive* laws);
- 2 the geometry of motion and distortion (kinematics); and
- 3 the laws of mechanics ($\mathbf{F} = m \mathbf{a}$, etc.)

Statics is the study of the effect of forces on rigid bodies, which are in equilibrium. Two forces are in equilibrium when they are equal, in opposing directions, and have the same line of action. In statics, a body is considered rigid when deformations, caused by acting forces, are negligibly small compared to the dimensions of the body. The main task of static analysis is to determine the equilibrium of the forces applied on a body or a mechanical system. Building on the axioms of mechanics, rigid-body mechanics deals with the equivalence and equilibrium of force systems, center of gravity calculations, internal forces, and moments in beams with problems on friction. Generally, the field looks at supporting structures that are at rest and that must remain at rest owing to their function. Material properties are not considered in statics; these are covered by strength of materials.

The concept of the force

All normal human beings are familiar in the day-to-day activities with the notion of the force. The opening or the closing of doors and the lifting of the weights are experiences which require one to exert force. Force may be defined as any action that tends to change the state of rest or motion of a body to which it is applied, that is, a force is a vector quantity.

The three quantities required to completely define force are called its specification or characteristics. So the characteristics of a force are:

1. Magnitude
2. Point of application
3. Direction of application

Line of action of force

The direction of a force is the direction, along a straight line, through its point of application in which the force tends to move a body when it is applied. This line is called *line of action of force*.

Representation of force

Graphically a force may be represented by the segment of a straight line. In mechanics as in everyday experiences, forces are usually produced by the action of one body on another. Since forces are vector quantities, they will be represented by bold-face letters such as **S** and **W**.

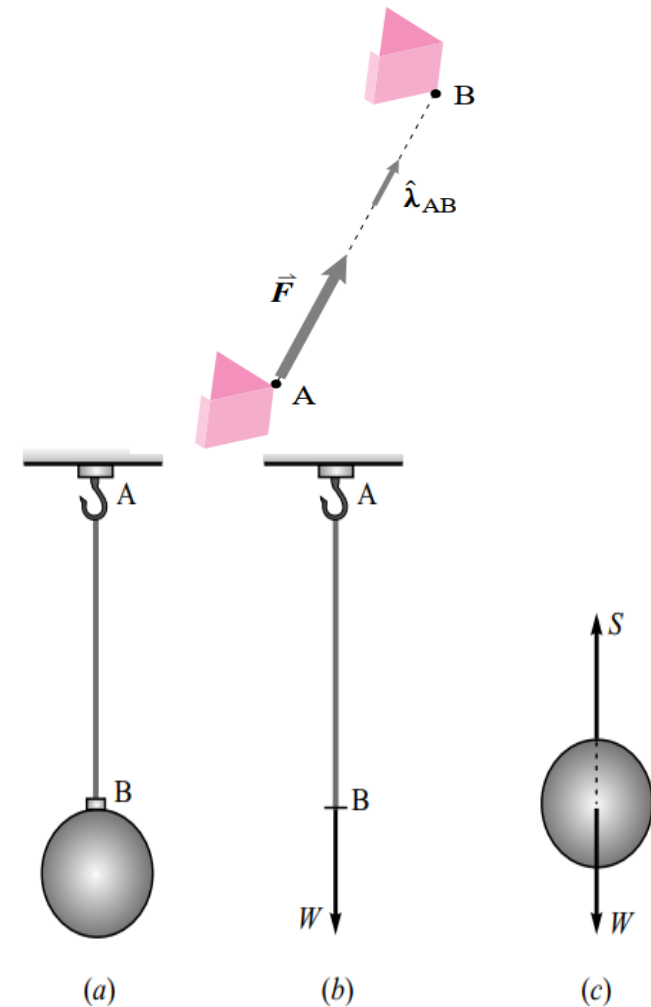

A ball of weight W hanging by a string.

System of forces

When more than one force acts on a body at a particular instant. They are said to constitute a system of force. Within the system forces, all the forces may lie on the same plane or on different planes. If they all lie on the same plane, they are said **Coplanar** forces. If they all lie on different planes. They are said to be **Non-Coplanar** forces. Further, if the lines of action of all them intersect at a point as in figure 2. They are termed **concurrent forces**. If not they are termed **non-concurrent forces**. Again, if the action of lines of all lie along the same line as in fig.2. They are termed **collinear**; and if their lines of action are parallel to each other as in Fig.2 they are termed **parallel** forces.

Characteristics of the Forces Systems

DESCRIPTION

COPLANAR FORCES

FORCES IN SPACES

i) Collinear Forces



ii) Parallel Forces



ii) Concurrent Forces



iv) Non-Concurrent Forces and non-Parallel Forces



No to possible have

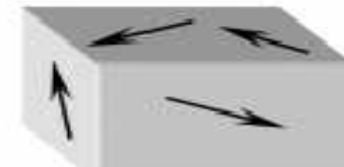
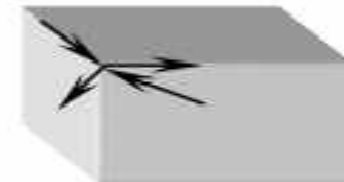
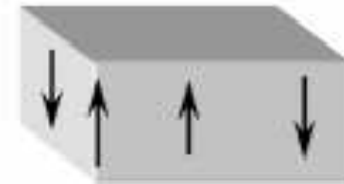

Fig.2 Graphical representation of various system of forces.

The resultant of system of forces

The resultant of addition of two forces depends not only on their magnitudes, but also on their directions.

The resultant action of a group or system of forces. Most problems in mechanics deal with a system of forces, and it is usually necessary to reduce the system to its simplest form to describe its action. The resultant of a system of forces is the simplest force combination which can replace the original forces without altering the external effect on the rigid body to which the forces are applied.

Resultant of Coplanar concurrent forces

Various methods are employed to determine the resultant of concurrent forces in a plane. They are describe below :

- a) **Graphical methods:** Parallelogram law, triangle law and polygon law;
- b) **Trigonometric methods:** Cosine law and sine law;
- c) **Analytical :** Vector approach.

Parallelogram law

The two component forces \mathbf{F}_1 and \mathbf{F}_2 acting on the pin in Fig.3 *a* can be added together to form the resultant force $\mathbf{F}_R = \mathbf{F}_1 + \mathbf{F}_2$, as shown in Fig.3 *b*. From this construction, or using the triangle rule, Fig. *c*, we can apply **the law of cosines** or **the law of sines** to the triangle in order to obtain the magnitude of the resultant force and its direction.

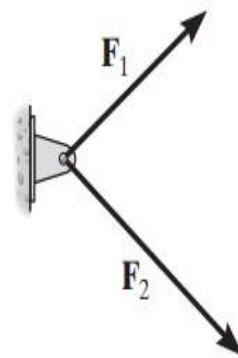
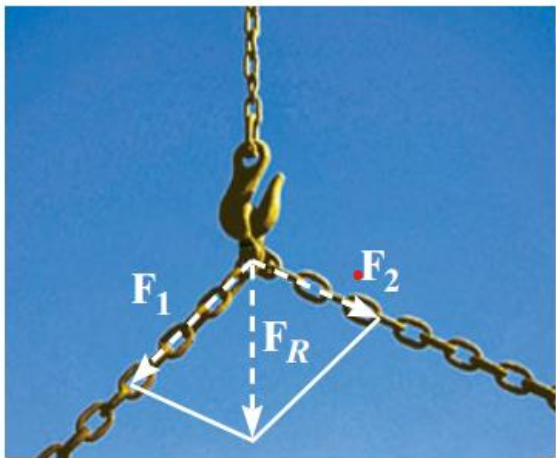

(a)

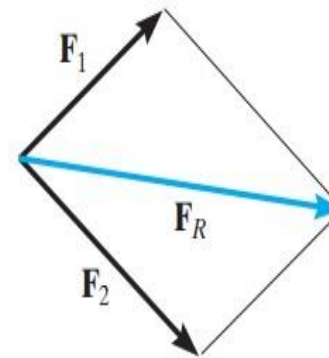

(b)

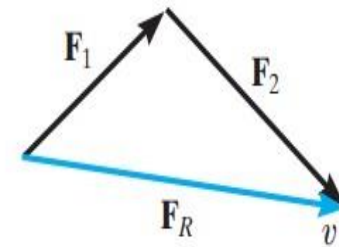

$$\mathbf{F}_R = \mathbf{F}_1 + \mathbf{F}_2$$

(c)

Fig.3 The parallelogram law must be used to determine the resultant of the two forces acting on the hook.

Trigonometry.

- Redraw a half portion of the parallelogram to illustrate the triangular head-to-tail addition of the components.
- From this triangle, the magnitude of the resultant force can be determined using the law of cosines, and its direction is determined from the law of sines. The magnitudes of two force components are determined from the law of sines. The formulas are given in Fig.4.

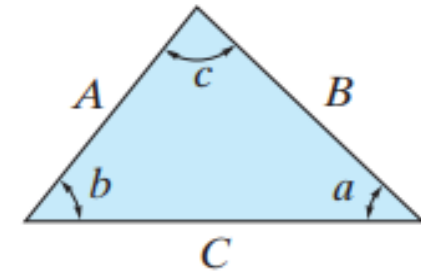

Cosine law:

$$C = \sqrt{A^2 + B^2 - 2AB \cos c}$$

Sine law:

$$\frac{A}{\sin a} = \frac{B}{\sin b} = \frac{C}{\sin c}$$

The polygon Law

To add more than two vectors, the parallelogram can be used by adding two vectors at a time and then continuing the process. Fig.5 shows the process of adding four P, Q, R, R_f.

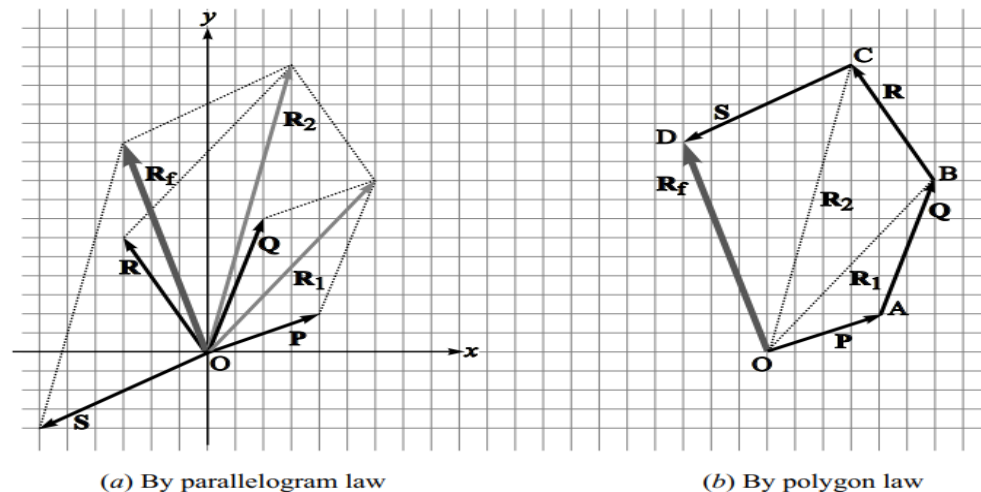

Fig.5. Addition of more than two vectors.

Fig.4.

Analytical Method

Figure 6 shows two forces P and Q inclined at an angle θ and acting at a common point O . We can construct the parallelogram $OACB$ to find the resultant R given by the diagonal OC . The resultant R makes an angle α with the vector P and an angle β with the vector O . From the point C , let us drop a perpendicular CM on t .

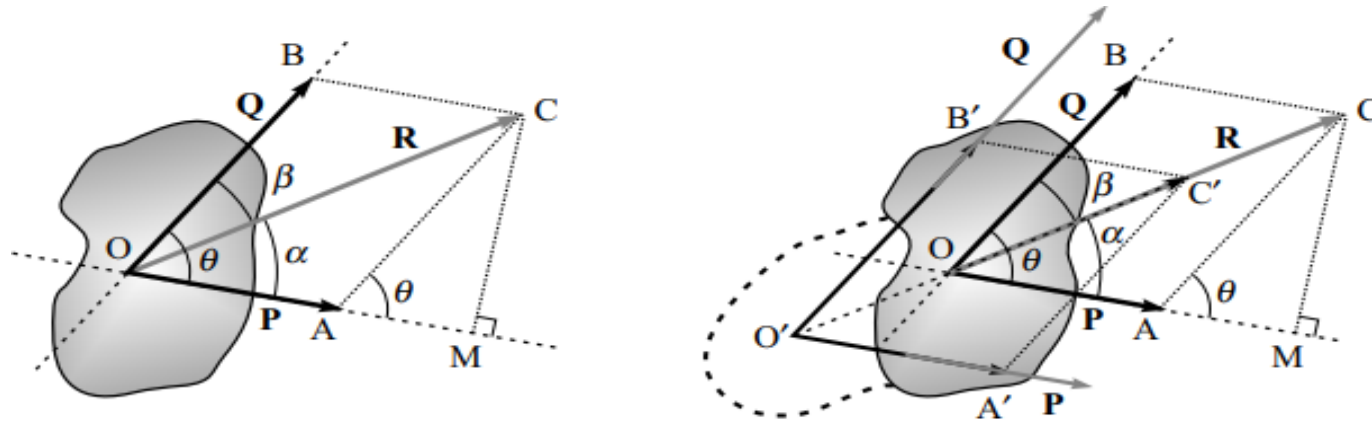

Fig.6. Analytical method..

Magnitude of the resultant:

The magnitude of the resultant force R can be found by:

$$\text{or} \quad R^2 = P^2 + Q^2 + 2PQ \cos \theta$$

$$\Rightarrow \quad R = \sqrt{P^2 + Q^2 + 2PQ \cos \theta}$$

Orientation of the resultant:

The angle α made by the resultant R with the component P can be found from the triangle OMC :

$$\tan \alpha = \frac{CM}{OM} = \frac{CM}{OA + AM} = \frac{AC \sin \theta}{OA + AC \cos \theta}$$

or

$$\tan \alpha = \frac{Q \sin \theta}{P + Q \cos \theta}$$

Example.1:

Find the magnitude and direction of the resultant of two forces of 100 N and 150 N acting at angle 45° .

Solution Given: $P = 100$ N, $Q = 150$ N, $\theta = 45^\circ$.

The magnitude of the resultant,

$$R = \sqrt{P^2 + Q^2 + 2PQ \cos \theta} = \sqrt{100^2 + 150^2 + 2 \cdot 100 \cdot 150 \cos 45^\circ} = \mathbf{232 \text{ N}}$$

The angle α between the resultant and the force of 100 N is given by

$$\tan \alpha = \frac{Q \sin \theta}{P + Q \cos \theta} = \frac{150 \sin 45^\circ}{100 + 150 \cos 45^\circ} = 0.515$$

$$\therefore \alpha = \tan^{-1} 0.515 = \mathbf{27.24^\circ}$$

Two-Dimensional Force Systems

The Components of a Force

Sometimes it is necessary to resolve a force into **two components** in order to study its pulling or pushing effect in two specific directions. For example, in Fig.6.a, \mathbf{F} is to be resolved into two components along the two members, defined by the u and v axes. In order to determine the magnitude of each component, a parallelogram is constructed first.

The force components \mathbf{F}_u and \mathbf{F}_v are then established by simply joining the tail of \mathbf{F} to the intersection points on the u and v axes, Fig.6.b. This parallelogram can then be reduced to a triangle, which represents the triangle rule, Fig.6.c. From this, the law of sines can then be applied to determine the unknown magnitudes of the components.

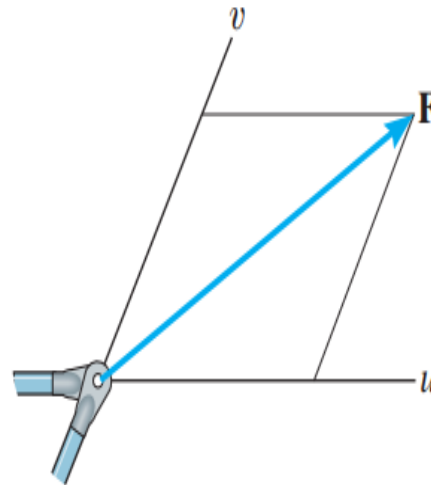
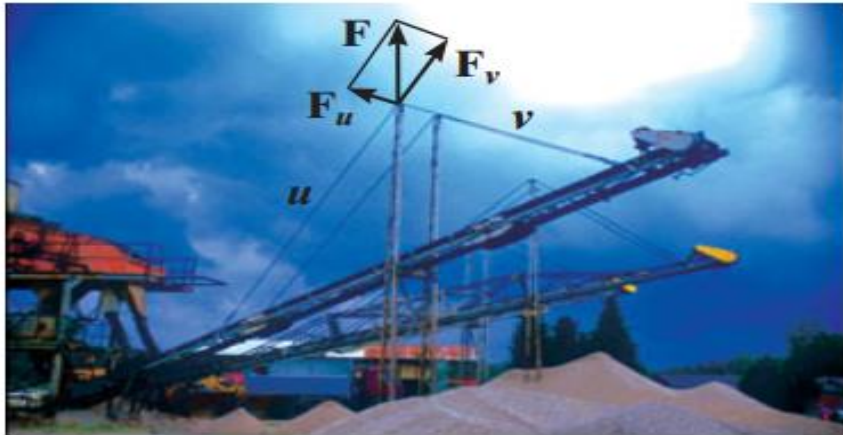

(a)

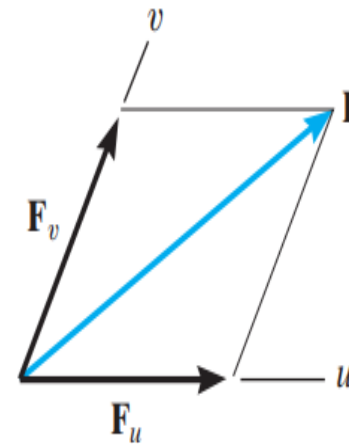

(b)

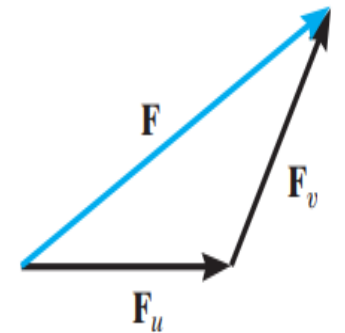

(c)

Fig.6 Using the parallelogram law force

\mathbf{F} caused by the vertical member can be resolved into components acting along the suspension cables a and b .

Rectangular Components

Analytical method

Decomposition of two forces

The most common two-dimensional resolution of a force vector is into rectangular components. It follows from the parallelogram rule that the vector \mathbf{F} of Fig.7. may be written as: $\mathbf{F} = \mathbf{F}_x + \mathbf{F}_y$ where \mathbf{F}_x and \mathbf{F}_y are *vector components* of \mathbf{F} in the x and y directions. $\mathbf{F}_x = F_x \mathbf{i}$ and $\mathbf{F}_y = F_y \mathbf{j}$, and thus we may write

$$\mathbf{F} = F_x \mathbf{i} + F_y \mathbf{j}$$

Fig.7.

For the force vector of Fig.7 the x and y scalar components are both positive and are related to the magnitude and direction of \mathbf{F} by

$$\begin{aligned} F_x &= F \cos \theta & F &= \sqrt{F_x^2 + F_y^2} \\ F_y &= F \sin \theta & \theta &= \tan^{-1} \frac{F_y}{F_x} \end{aligned}$$

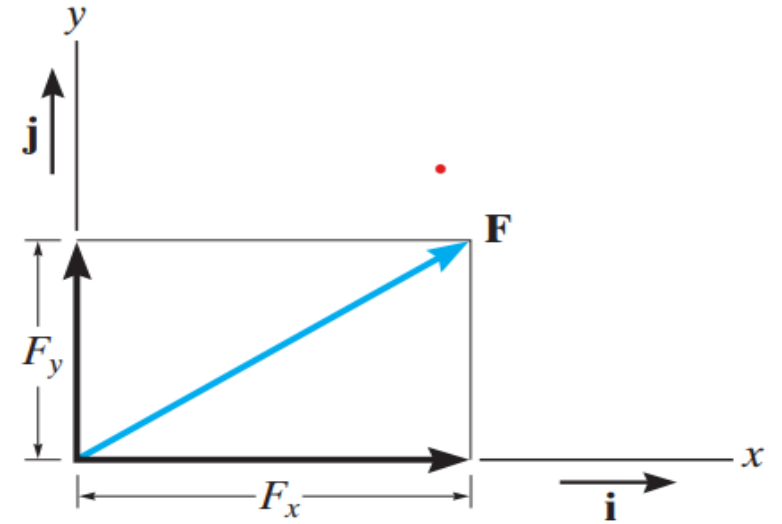
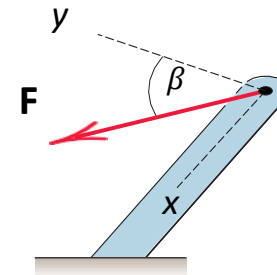

$$\begin{aligned} F_x &= F \sin \theta \\ F_y &= F \cos \theta \end{aligned}$$

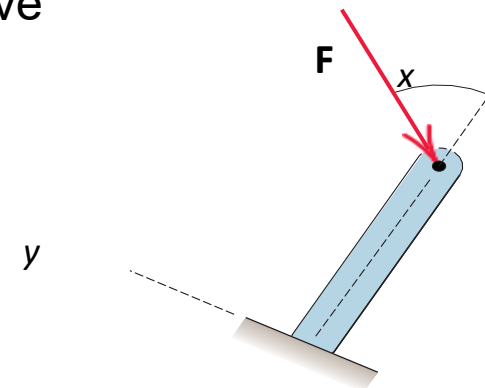

$$\begin{aligned} F_x &= -F \sin \theta \\ F_y &= -F \cos \theta \end{aligned}$$

- Consider two forces \mathbf{F}_1 and \mathbf{F}_2 which are originally concurrent at a point O . Figure 5 shows the line of action of \mathbf{F}_2 shifted from O to the tip of \mathbf{F}_1 according to the triangle rule of Fig. 2. In adding the force vectors \mathbf{F}_1 and \mathbf{F}_2 , we may write

$$\mathbf{R} = \mathbf{F}_1 + \mathbf{F}_2 = (F_{1x} \mathbf{i} + F_{1y} \mathbf{j}) + (F_{2x} \mathbf{i} + F_{2y} \mathbf{j})$$

$$\text{or } R_x \mathbf{i} + R_y \mathbf{j} = (F_{1x} + F_{2x})\mathbf{i} + (F_{1y} + F_{2y}) \mathbf{j}$$

from which we conclude that

$$R_x = F_{1x} + F_{2x} = \Sigma F_x$$

$$R_y = F_{1y} + F_{2y} = \Sigma F_y$$

The term ΣF_x means “the algebraic sum of the x scalar components”. For the example shown in Fig.8. note that the scalar component F_2 would be negative.



The structural elements in the foreground transmit concentrated forces to the brackets at both ends

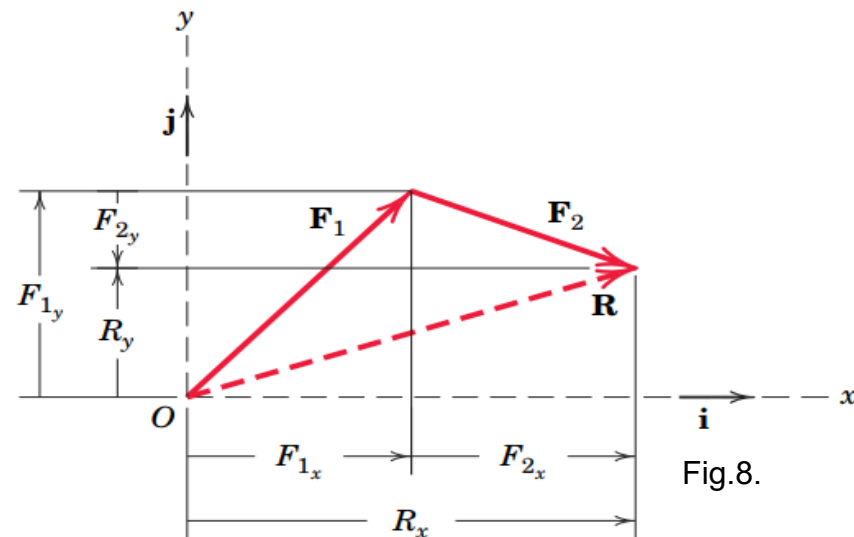

Fig.8.

Concurrent Forces

- Two or more forces are said to be *concurrent at a point* if their lines of action intersect at that point. The forces \mathbf{F}_1 and \mathbf{F}_2 shown in **Fig.a** have a common point of application and are concurrent at the point A.

Thus, they can be added using the parallelogram law in their common A plane to obtain their sum or *resultant* \mathbf{R} , as shown in **Fig.a**. The \mathbf{F}_2 resultant lies in the same plane as \mathbf{F}_1 and \mathbf{F}_2 .

- Suppose the two concurrent forces lie in the same plane but are applied at two different points as in **Fig.b**. By the principle of transmissibility, we may move them along their lines of action and complete their vector sum \mathbf{R} at the point of concurrency A, as shown in **Fig. b**. We can replace \mathbf{F}_1 and \mathbf{F}_2 with the resultant \mathbf{R} without altering the external effects on the body upon which they act.

- We can also use the triangle law to obtain \mathbf{R} , but we need to move the line of action of one of the forces, as shown in **Fig. c**. If we add the same two forces as shown in **Fig.d**, we correctly preserve the magnitude and direction of \mathbf{R} , but we lose the correct line of action, because \mathbf{R} obtained in this way does not pass through A. Therefore this type of combination should be avoided. We can express the sum of the two forces mathematically by the vector equation: $\mathbf{R} = \mathbf{F}_1 + \mathbf{F}_2$

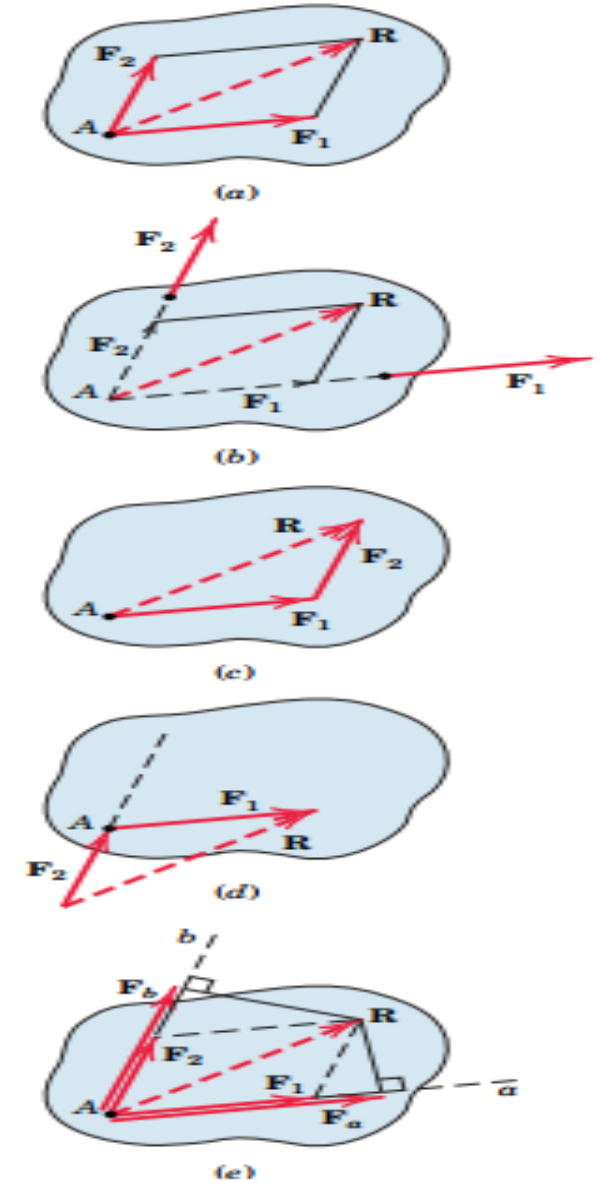

Coplanar Force Resultants.

We can use either of the two methods just described to determine the resultant of several *coplanar forces*.

The vector resultant is therefore

$$\mathbf{F}_R = \mathbf{F}_1 + \mathbf{F}_2 + \mathbf{F}_3$$

$$\begin{aligned} &= F_{1x}\mathbf{i} + F_{1y}\mathbf{j} - F_{2x}\mathbf{i} + F_{2y}\mathbf{j} + F_{3x}\mathbf{i} - F_{3y}\mathbf{j} \\ &= (F_{1x} - F_{2x} + F_{3x})\mathbf{i} + (F_{1y} + F_{2y} - F_{3y})\mathbf{j} \\ &= (F_{Rx})\mathbf{i} + (F_{Ry})\mathbf{j} \end{aligned}$$

$$\mathbf{F}_1 = F_{1x}\mathbf{i} + F_{1y}\mathbf{j}$$

$$\mathbf{F}_2 = -F_{2x}\mathbf{i} + F_{2y}\mathbf{j}$$

$$\mathbf{F}_3 = F_{3x}\mathbf{i} - F_{3y}\mathbf{j}$$

$$F_{Rx} = \sum F_x$$

$$F_{Ry} = \sum F_y$$

If *scalar notation* is used, then we have

$$F_{Rx} = F_{1x} - F_{2x} + F_{3x}$$

$$F_{Ry} = F_{1y} + F_{2y} - F_{3y}$$

These are the *same* results as the \mathbf{i} and \mathbf{j} components of \mathbf{F}_R determined above.

We can represent the components of the resultant force of any number of coplanar forces symbolically by the algebraic sum of the x and y components of all the forces, i.e.,

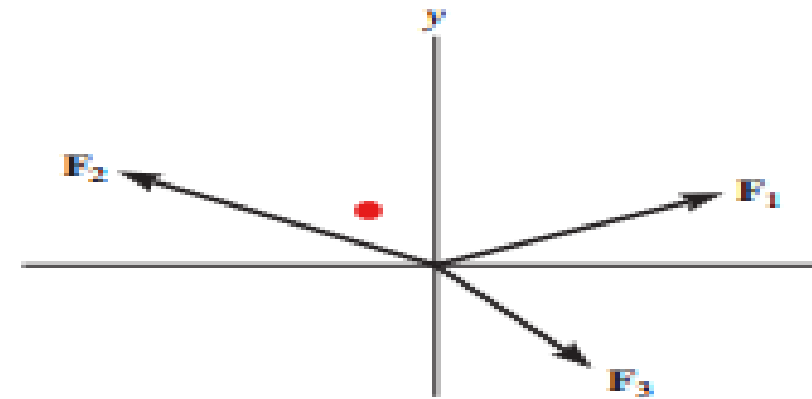

(a)

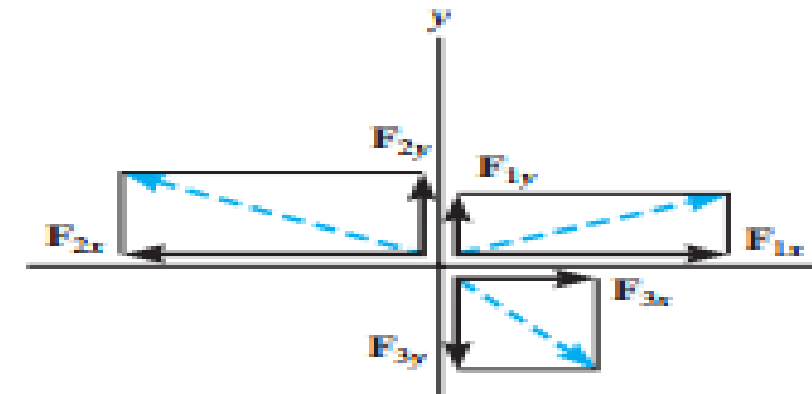

(b)

As shown in Fig. From this sketch, the magnitude of \mathbf{F}_R is then found from the Pythagorean theorem; that is,

$$F_R = \sqrt{F_{Rx}^2 + F_{Ry}^2}$$

Also, the angle θ , which specifies the direction of the resultant force, is determined from trigonometry

$$\theta = \tan^{-1} \left| \frac{F_{Ry}}{F_{Rx}} \right|$$

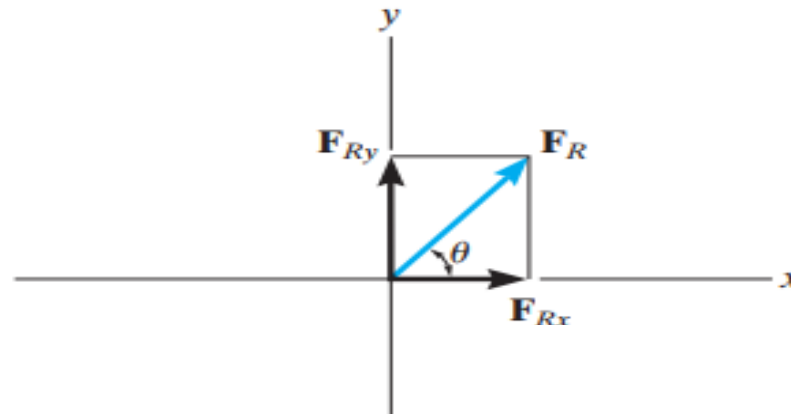

Example.2:

The maintain an electric pole AB upright, a guy wire AC is tied to it, as shown in figure 9. The guy wire makes an angle of 60° to the horizontal and exerts a force of 20 kN on the pole. Find the horizontal and vertical components of this force.

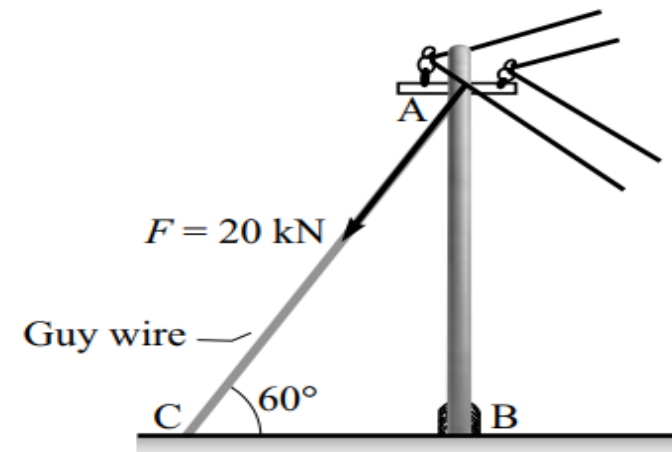

(a) Electric pole

Solution: The resolution of the force F exerted by the guy wire is shown in figure.(b).The two components are given as:

$$F_H = F \cos 60^\circ = 20 \cos 60^\circ = 10 \text{ kN.}$$

$$F_V = F \sin 60^\circ = 20 \sin 60^\circ = 17.32 \text{ kN.}$$

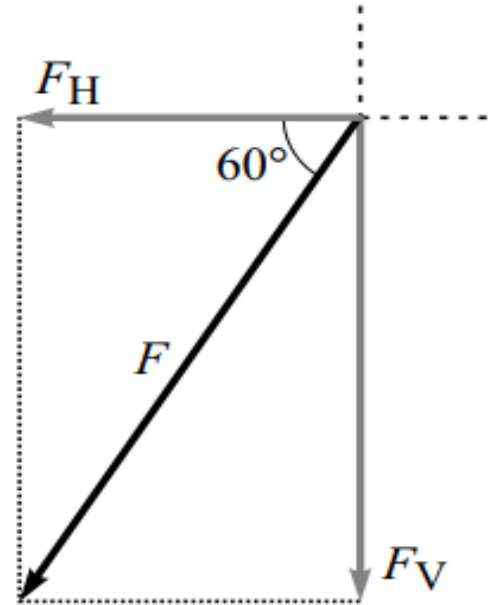

(b) Resolution of force F

Three-Dimensional Force Systems

Concurrent force in space

Rectangular Components

Many problems in mechanics require analysis in three dimensions, and for such problems it is often necessary to resolve a force into its three mutually perpendicular components. The force F acting at point O in Fig.7 has the rectangular components F_x , F_y , F_z , where

$$F_x = F \cos \theta_x$$

$$F_y = F \cos \theta_y$$

$$F_z = F \cos \theta_z$$

$$\mathbf{F} = F(\cos \theta_x \mathbf{i} + \cos \theta_y \mathbf{j} + \cos \theta_z \mathbf{k})$$

Cartesian Vectors

The unit vector \mathbf{u} has a length of one, no units, and it points in the direction of the vector \mathbf{F} .

A force can be resolved into its Cartesian components along the x , y , z axes so that

$$\mathbf{F} = F_x \mathbf{i} + F_y \mathbf{j} + F_z \mathbf{k}$$

$$\|\vec{F}\| = F = \sqrt{F_x^2 + F_y^2 + F_z^2}$$

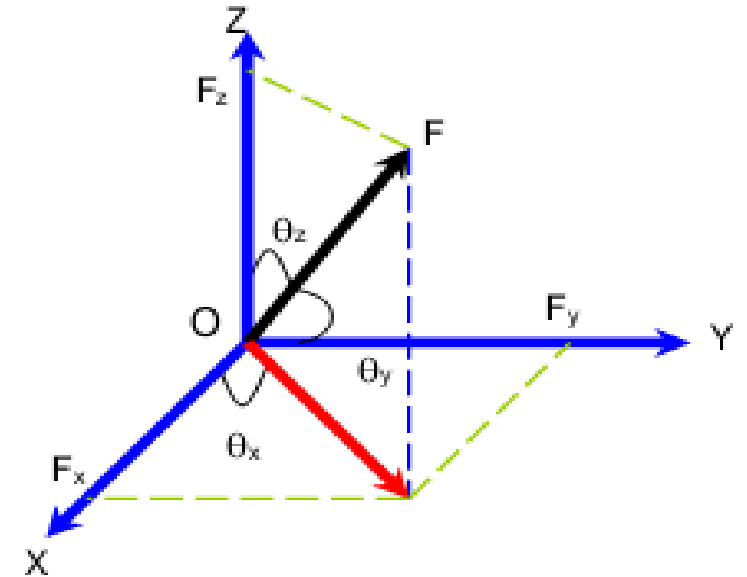

To find the resultant of concurrent force system, express each force as a Cartesian vector and add the i, j, k components of all the forces in the system.

If the line of action of a force passes through points A and B , then the force acts in the same direction as the position vector. Which is defined by the unit vector $\hat{\lambda}_A$. The force can then be expressed as a Cartesian.

An easy way to find a unit vector in the direction of a vector \vec{A} is to divide \vec{A} by its magnitude. This is a unit vector \hat{A} in the direction

$$\hat{\lambda}_A \equiv \frac{\vec{A}}{|\vec{A}|}$$

A common situation is to know that a force \vec{F} is a yet unknown scalar F multiplied by a unit vector pointing between known points A and B . (fig.10).

We can then write as

$$\vec{F} = F\hat{\lambda}_{AB} = F \frac{\vec{r}_{AB}}{|\vec{r}_{AB}|} = F \frac{\vec{r}_B - \vec{r}_A}{|\vec{r}_B - \vec{r}_A|} = F \left(\frac{(x_B - x_A)\mathbf{i} + (y_B - y_A)\mathbf{j} + (z_B - z_A)\mathbf{k}}{\sqrt{(x_B - x_A)^2 + (y_B - y_A)^2 + (z_B - z_A)^2}} \right)$$

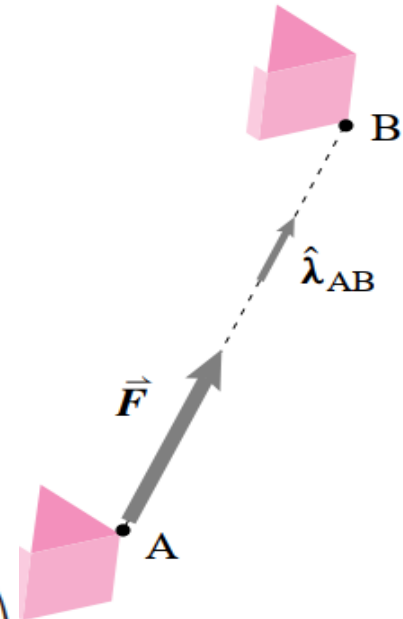
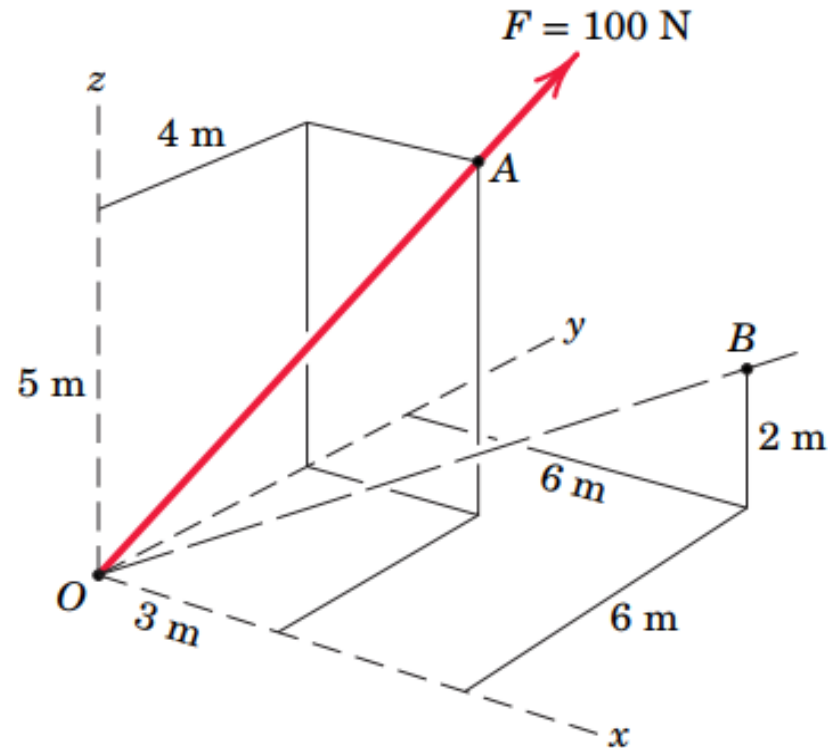

Fig.10

Example 3:

- (a) Determine the x, y and z scalar components of the projection F_{xy} of \mathbf{F} on the x-y plane.
- (b) projection F_{xy} of \mathbf{F} on the x-y plane.
- (c) projection F_{OB} of \mathbf{F} along the line OB .



Solution Part (a). We begin by writing the force vector \mathbf{F} as its magnitude F times a unit vector \mathbf{n}_{OA} .

$$\begin{aligned}\mathbf{F} &= F\mathbf{n}_{OA} = F \frac{\vec{OA}}{OA} = 100 \left[\frac{3\mathbf{i} + 4\mathbf{j} + 5\mathbf{k}}{\sqrt{3^2 + 4^2 + 5^2}} \right] \\ &= 100[0.424\mathbf{i} + 0.566\mathbf{j} + 0.707\mathbf{k}] \\ &= 42.4\mathbf{i} + 56.6\mathbf{j} + 70.7\mathbf{k} \text{ N}\end{aligned}$$

The desired scalar components are thus

$$F_x = 42.4 \text{ N} \quad F_y = 56.6 \text{ N} \quad F_z = 70.7 \text{ N} \quad \odot \quad \text{Ans.}$$

Part (b). The cosine of the angle θ_{xy} between \mathbf{F} and the x - y plane is

$$\cos \theta_{xy} = \frac{\sqrt{3^2 + 4^2}}{\sqrt{3^2 + 4^2 + 5^2}} = 0.707$$

so that $F_{xy} = F \cos \theta_{xy} = 100(0.707) = 70.7 \text{ N}$ Ans.

Part (c). The unit vector \mathbf{n}_{OB} along OB is

$$\mathbf{n}_{OB} = \frac{\vec{OB}}{OB} = \frac{6\mathbf{i} + 6\mathbf{j} + 2\mathbf{k}}{\sqrt{6^2 + 6^2 + 2^2}} = 0.688\mathbf{i} + 0.688\mathbf{j} + 0.229\mathbf{k}$$

The scalar projection of \mathbf{F} on OB is

$$\begin{aligned}F_{OB} &= \mathbf{F} \cdot \mathbf{n}_{OB} = (42.4\mathbf{i} + 56.6\mathbf{j} + 70.7\mathbf{k}) \cdot (0.688\mathbf{i} + 0.688\mathbf{j} + 0.229\mathbf{k}) \quad \odot \\ &= (42.4)(0.688) + (56.6)(0.688) + (70.7)(0.229) \\ &= 84.4 \text{ N}\end{aligned} \quad \text{Ans.}$$

If we wish to express the projection as a vector, we write

$$\begin{aligned}\mathbf{F}_{OB} &= \mathbf{F} \cdot \mathbf{n}_{OB} \mathbf{n}_{OB} \\ &= 84.4(0.688\mathbf{i} + 0.688\mathbf{j} + 0.229\mathbf{k}) \\ &= 58.1\mathbf{i} + 58.1\mathbf{j} + 19.35\mathbf{k} \text{ N}\end{aligned}$$

